

# How will the Government's policy for new homes to be zero carbon from 2016 affect residential development?

Some Comments from a Developer

Steve Harper  
Group M&E Services Manager  
Galliard Homes Ltd.



# Uncertainty!

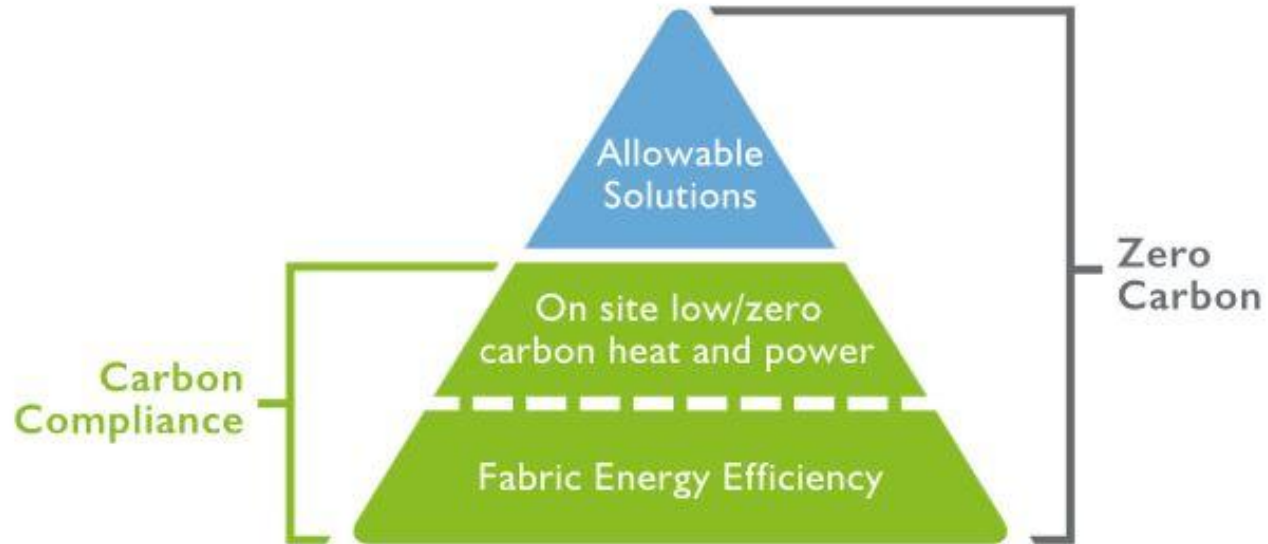

# Lessons Learnt

- LEAN use less energy
- MEAN use energy efficiently
- GREEN - use lower carbon emitting options

# Technical detail on systems

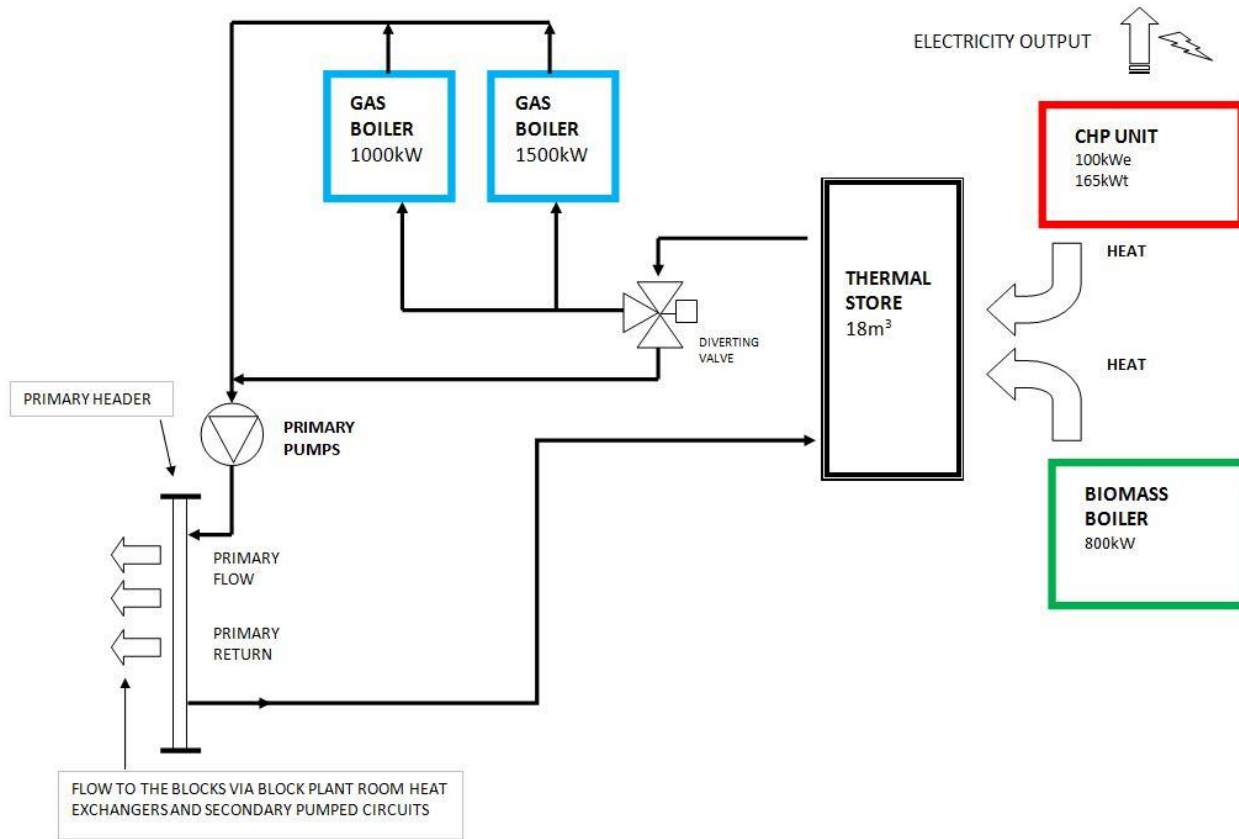

# Biomass???



# Community Heating Network Losses

## OPTIONS ON INCREASING INSULATION LEVELS

### FROM EXISTING INSULATION STANDARDS

<i>Calculated using Wm-1</i>	<i>From the various Standards</i>	<b>NETWORK LOSS kWh/ Annum</b>	<b>% REDUCTION IN kWh HEAT LOSS</b>		
		PART L 2006	144416	0	
		ECA & Y50 ENHANCED	130174	10	%
		EN253 SERIES 1	120256	17	%
		EN253 SERIES 2	105171	27	%
		EN253 SERIES 3	89492	38	%

# On-site - Measures

*‘even where on-site measures may be technically feasible, they can be expensive and may not be cost effective in comparison with off-site carbon abatement measures’*

**DCLG Next steps to zero carbon homes – Allowable Solutions  
Impact Assessment – August 2013**



# Menu - Allowable Solutions

1. 100% of AS carbon abatement on site
2. Off-site carbon abatement – the developer ‘do-it-yourself’ option
3. Contract with a third party Allowable Solutions provider (including Local Authority)
4. Making a payment which is directed to a fund which then invests in projects which will deliver carbon abatement on their behalf



# Legislation

*Section 37 of the Infrastructure Act 2015 to provide powers in the Building Act to enable Building Regulations to be made covering offsite carbon abatement measures*

# Governance + Validation + Verification

- Carbon Pricing
- AS Really a worthy option? it needs more time to configure the mechanisms??
- Impact assessment side-steps a lot of issues
- Certification provided to Building control approved inspectors?

# Summary

1. Marketing LZC homes- no benefits
2. High-rise apartments technical solutions and targets are unclear
3. AS National Framework
4. Small sites exemption
5. Is AS a 'tax and spend' measure?
6. One in/ Two out for Business Regulation